

Main Components – Early Style

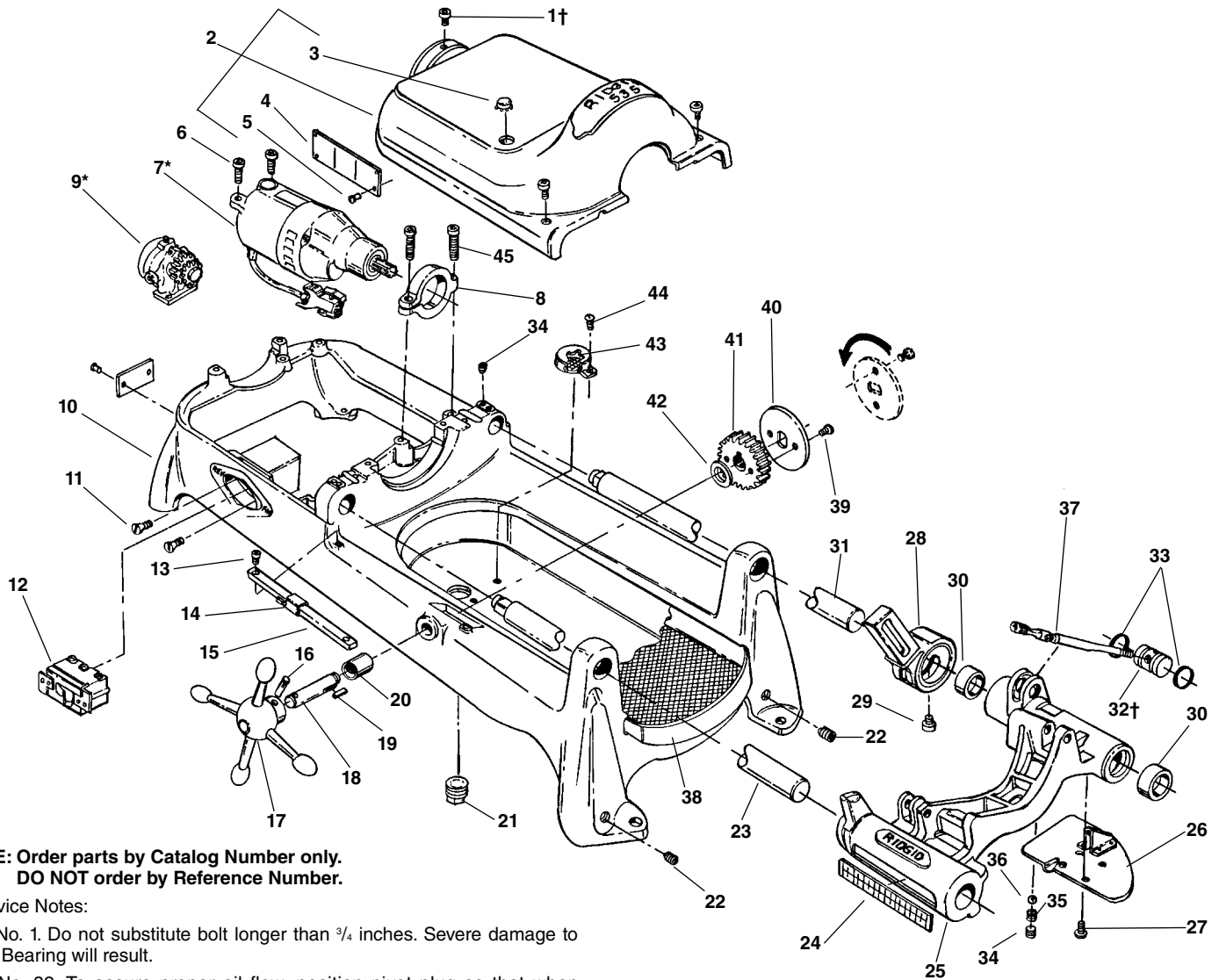

**NOTE: Order parts by Catalog Number only.
DO NOT order by Reference Number.**

†Service Notes:

Ref. No. 1. Do not substitute bolt longer than $\frac{3}{4}$ inches. Severe damage to Rear Bearing will result.

Ref. No. 32. To assure proper oil flow, position pivot plug so that when spout is in up position, oil flow hole is visible in carriage slot below spout.

Ref. No.	Catalog No.	Description	Ref. No.	Catalog No.	Description
1†	46760	Screw $\frac{3}{8}$ " - 16 x $\frac{3}{4}$ " (3)	24	46370	Scale
2	43190	Cover (Incls. Ref. No. 3, 4, 5)	25	62057	Carriage Assy. (Includes Ref. Nos. 24, 26, 27, 28, 29, 30, 34, 35, 36)
3	89310	Plug Button	26	45195	Drip Plate
4	88690	Warning Plate	27	46270	Screw $\frac{1}{4}$ " - 20 x $\frac{1}{2}$ " Pan Head (4)
5	85920	Pop Rivet (8)	28	43690	Cutter Arm
6	46745	Screw $\frac{3}{8}$ " - 16 x $1\frac{1}{4}$ " (2)	29	44930	Screw, $\frac{5}{16}$ " x $\frac{9}{32}$ "
7*	88125	Motor Model 1177, 115V	30	46720	Oil Seal (2)
	88165	Motor Model 2377, 230V	31	45220	Support Bar - Rear
8	43795	Motor Bracket	32†	44340	Pivot Plug
9*	47195	Model A Oil Pump	33	44470	O-Ring (2)
10	43030	Base (Incls. Ref. No. 20, 21, 22, 44)	34	46800	Set Screw $\frac{3}{8}$ " - 16 x $\frac{3}{8}$ " (3)
11	45280	Screw #8-32 x $\frac{3}{8}$ " Flat Head (2)	35	46680	Spring
12	44505	Switch	36	46925	Ball
13	45615	Screw #10-32 x $\frac{1}{2}$ " Flat Head (2)	37	44495	Oil Spout Assembly
14	47110	Indicator Slide	38	43355	Chip Tray
15	47105	Indicator Bar	39	46785	Screw #10-32 x $\frac{3}{8}$ "
16	47165	Pin	40	47120	Lock Plate
17	46510	Handwheel	41	45430	Pinion
18	47115	Pinion Shaft	42	47145	Spacer
19	46930	Key $\frac{3}{16}$ " Square	43	46655	Filter
20	46540	Bushing	44	45420	Screw #10-24 x $\frac{3}{8}$ "
21	44485	Drain Plug	45	44220	Screw $\frac{3}{8}$ " - 16 x $1\frac{1}{2}$ "
22	42037	Set Screw $\frac{1}{2}$ " - 13 x $\frac{1}{2}$ " (4)			
23	45440	Support Bar - Front			

*Refer to Motor Model No./Refer to Model "A" Oil Pump for Component Parts

Main Components

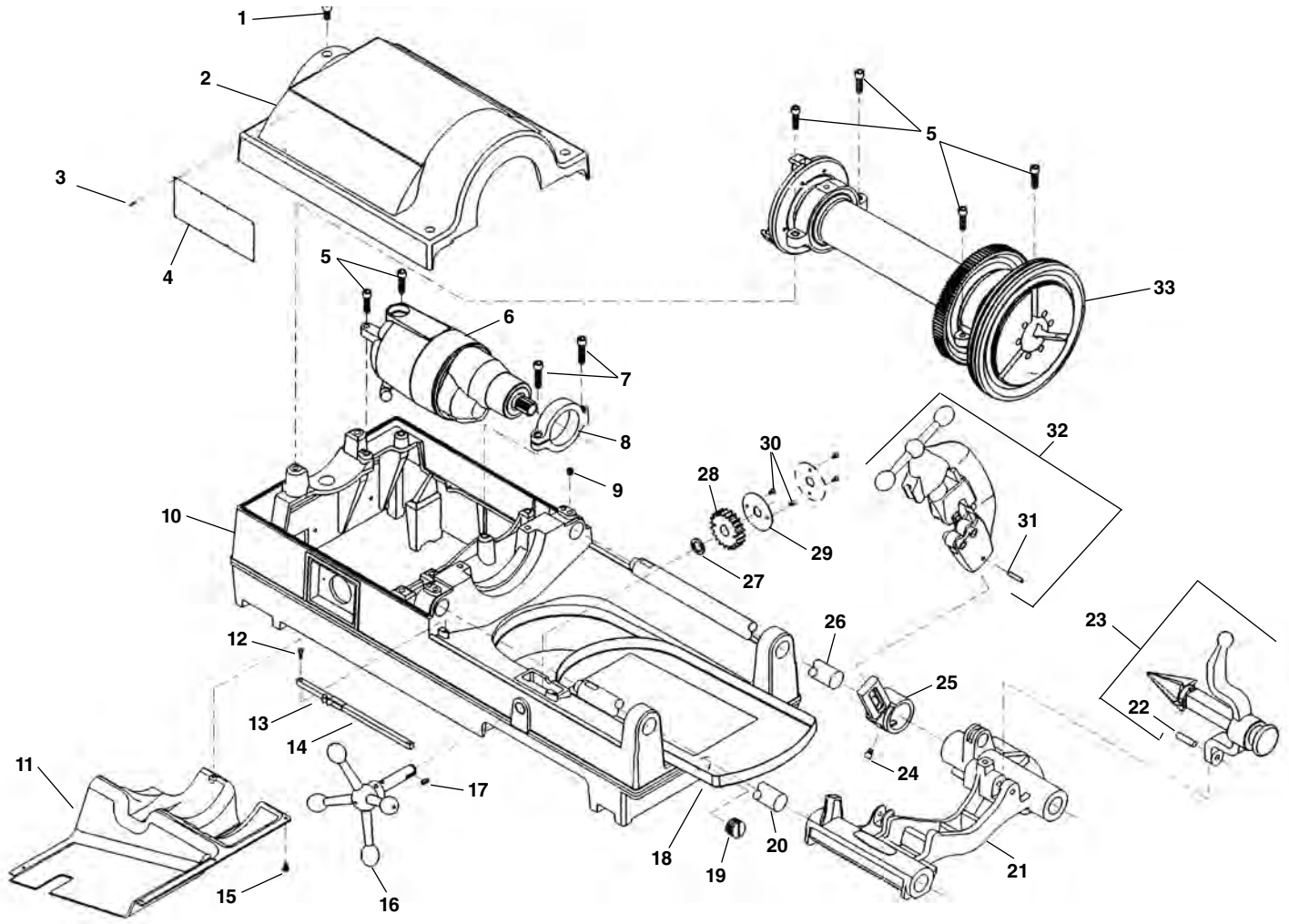

**NOTE: Order parts by Catalog Number only.
DO NOT order by Reference Number.**

Ref. No.	Catalog No.	Description	Ref. No.	Catalog No.	Description
1	46760	Screw (3)	17	46930	Key 3/16" Sq. x 1/2"
2	62062	Top Cover	18	43355	Chip Tray
3	85920	Pop Rivet (8)	19	48337	Drain Plug
4	88690	Warning Plate	20	45440	Front Support Bar
5	46745	Screw	21	62057	Carriage Assembly
6	64447	1194 Motor, 115V, 36 RPM	22	47065	Hinge Pin
—	64452	1194 A Motor, 115V, 54 RPM	23	42365	341 Reamer Assembly
—	64457	2394 Motor, 230V, 36 RPM	24	44930	Stop Screw
7	44220	Screw (2)	25	43690	Cutter Arm
8	43795	Motor Bracket	26	45220	Rear Support Bar
9	46800	Set Screw (2)	27	47145	Spacer
10	61952	Base	28	45430	Pinion Gear
11	61947	Bottom Cover	29	47120	Lock Plate
12	45615	Screw (2)	30	46785	Screw 10 - 32 x 3/8" (2)
13	47110	Indicator Slide	31	47135	Stop Pin
14	47105	Indicator Bar	32	42390	820 Cutter Assembly
15	45420	Screw (5)	33	47585	Drive Shaft Assembly
16	46510	Handwheel			